

Instruction for the QC measurement

1	The start:.....	1
10	The definition for the Rub & Buss measurement.....	2
23	The definition for the SPL measurement	5
42	The definition for the THD measurement	7
52	The definition for the polarity test.....	9
59	The Quality Control measurement	10
65	Appendix	12

© 2007 Copyright Kirchner elektronik

For the testing of the speaker with the ATB QC program there is a need of a quiet room. At the production line the surrounding noise can be dropped down by a test box. The drawing of the test box is in the attachment.

The measurement is done in the near field.

1 The start:

1. Open the ATB QC program.
2. The microphone is placed in the near field. Connect the microphone and the speaker to the ATB 701 instrument.

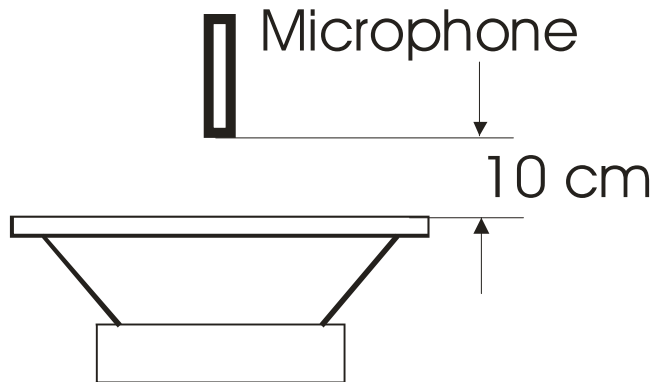

3. The ATB 701 instrument is switched to SPL

5. In the parameter menu, to open with , the Smooth parameter is set to 1/12.

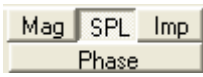
6. In the program the  measurement is set.

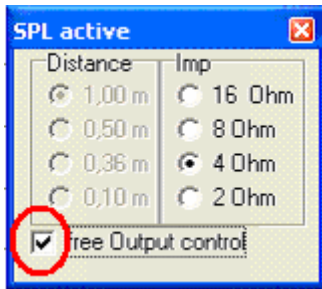

7. In the „free output control” is to activate.

8. The measurement is to start with the  button.

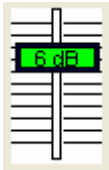
9. The level of the output is set  with the output controller. The output is to rise as

long, as the bar of the input level meter  gets green

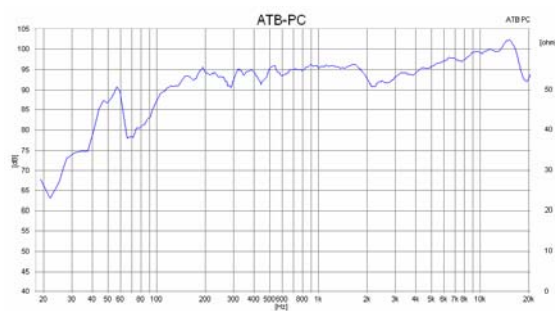

and the curve is at the top of the plot.

10 The definition for the Rub & Buss measurement

Attention: The definition for the Rub & Buss measurement is to do first.

10. Open the Intermodulation measurement with the  button.

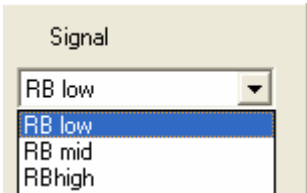
11. First the range for the  measurement is to set.
 RB low for woofer
 RB mid for midrange speaker
 RB high for tweeter

The value of the Q-Index is shown below the Refmeas button.

19. The tolerance is to set in the  window.

Example for the calculation of the tolerance:

The Q-Index of the no defect speaker is 1043. Only the speakers without defect with the Q-Index > 1025 shall pass. The tolerance is to set with $1043 - 1025 = 18$.

If the speakers with a small defect and a Q-Index = 950 shall pass, the tolerance is $1043 - 950 = 93$

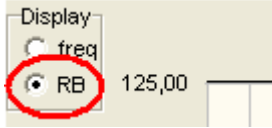
20. For the test measurement the plot is switched to  RB.

21. The test measurement is to start with the .

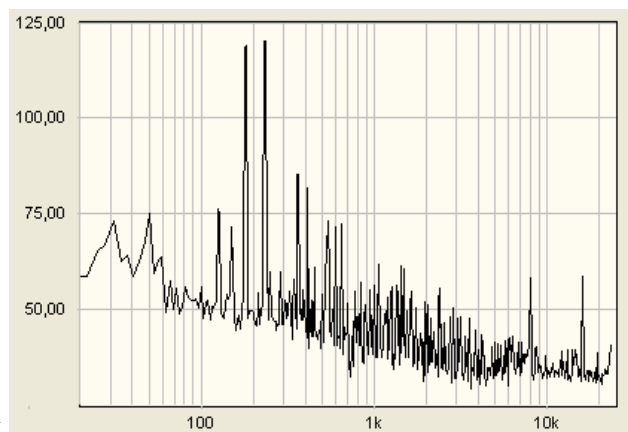

The measurement is shown in the plot.

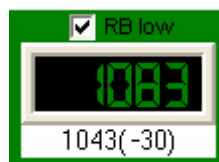

In the display for the result the Q-Index of the tested speaker is shown. Below there is the Q-Index of the reference speaker and the tolerance.

22. After going back in the definition menu with ,

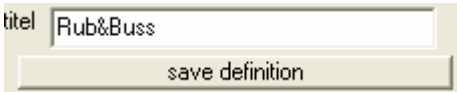
the definition is described  and saved.

The definition file gets the name of the speaker.

Attention: the file name does not begin with a number.

23 The definition for the SPL measurement

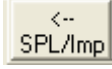
23. After returning to the SPL measurement with the  button, you will get the measurement from step 1 – 9. This is for the start of the SPL definition.

24. Another speaker is connected for measurement.

The measurement is to start with the + measurement  . Up to 32 speakers can be measured with this function.

25. The plot shows the curves of the 32 speakers.

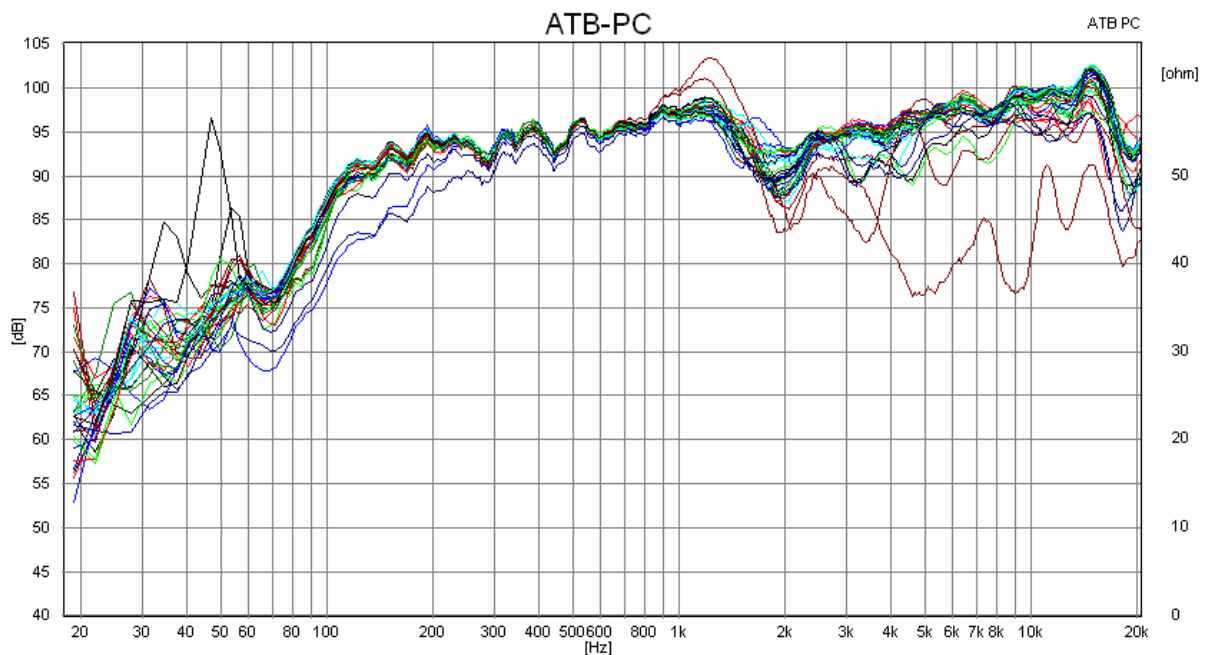

Most of the curves are nearly the same. Some blue, brown and red curves are different to the main curves. They show defect speakers.

Below 80Hz the curves are dropped and their difference is great. In this part of the plot the sound pressure is so low that the surrounding noise is measured. This part has no importance for the test measurement. Therefore it can be put of the definition.

In the range 80Hz – 1,2kHz the curves of the no defect speakers lie closely together. The tolerance is $\pm 1,5$ dB.

In the range 1,2kHz – 7kHz the tolerance is ± 3 dB.

In the range 7kHz - 20kHz the tolerance is spread to $\pm 4,5$ dB.

This values will be used for the definition.

26. For further processing the curves are saved with  .

27. For the reference speaker a new measurement is started with  .

28. The QC measurement is to open with the  button.

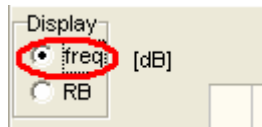

29. In the measurement the plot is switched to  SPL.

30. In the case that the Rub & Buss definition is not shown,



it is to load with load definition

31. The definition menu is to open with .

33. There is to check if the SPL measurement is set. 

34. With the  the reference measurement is to transfer in the definition.

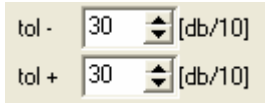
35. In the menu a  mean tolerance of ± 3 db is to set.

36. To put out the range below 80Hz out of the definition edit upper ref is to activate.

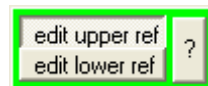

. In the plot the cursor is set to 80Hz. This can be controlled in the window for

the cursor values. 

With a click at the right mouse button the limit is set.

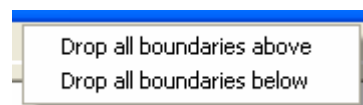
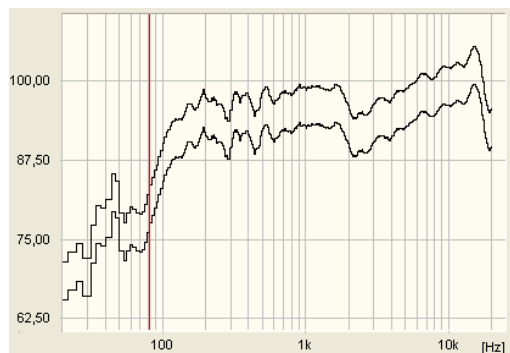

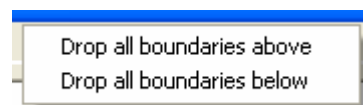
In the  menu is to select: „Drop all boundaries below“.

37. Then the thresholds are to set. Above 7.5kHz the tolerance should be $\pm 4,5$ dB. To edit the upper threshold it is to drag with the left mouse button pushed down.

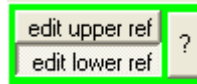

To edit the lower threshold it is to activate in

38. After the setting of the Thresholds they are tested with a test measurement. For it, the reference speaker is connected to the ATB 701 instrument. The measurement is started with

the  button.

The curve is shown between the thresholds.

39. At some points the reference curve will be near to the thresholds. At these points the curves

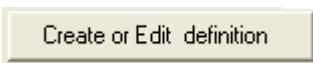
are to edit. After opening the definition menu with  the threshold is to

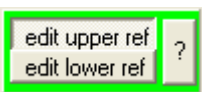
select  and to drag with the left mouse button pushed down.

40. For the following measurements with non defect speakers to start with

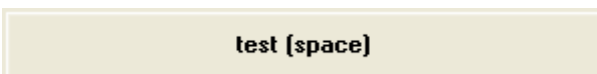
 the result window has to show passed. If not the thresholds are to be edited with the process described above.

41. In the title window the name of the speaker and the conditions for the test are to write.

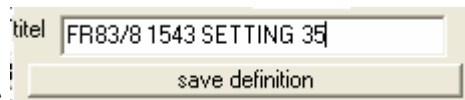

Then the definition is to save:

42 The definition for the THD measurement

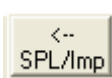
42. After returning to the SPL measurement with the  button, you will get the measurement from step 1 – 9. This is for the start of the SPL definition.

43. The THD measurement is to open .

44. In the THD measurement following parameter are to set:

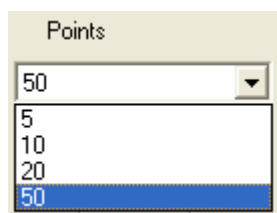

In the points menu the number of test frequencies with 50 is to set.

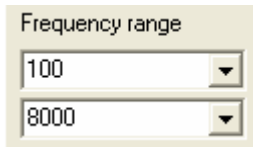

In the frequency range menu the range of the SPL reference measurement from point 25 is to set. The start frequency is when the curve is nearly at the maximum at 100Hz. The high frequency is at 8kHz. It is the limit for the THD measurement.

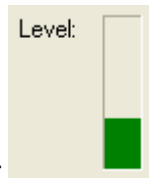

The level meter is for the control of the input level. If it is read, there is an error in the measurement.

45. The curve shows the harmonic distortion of the speaker in %.

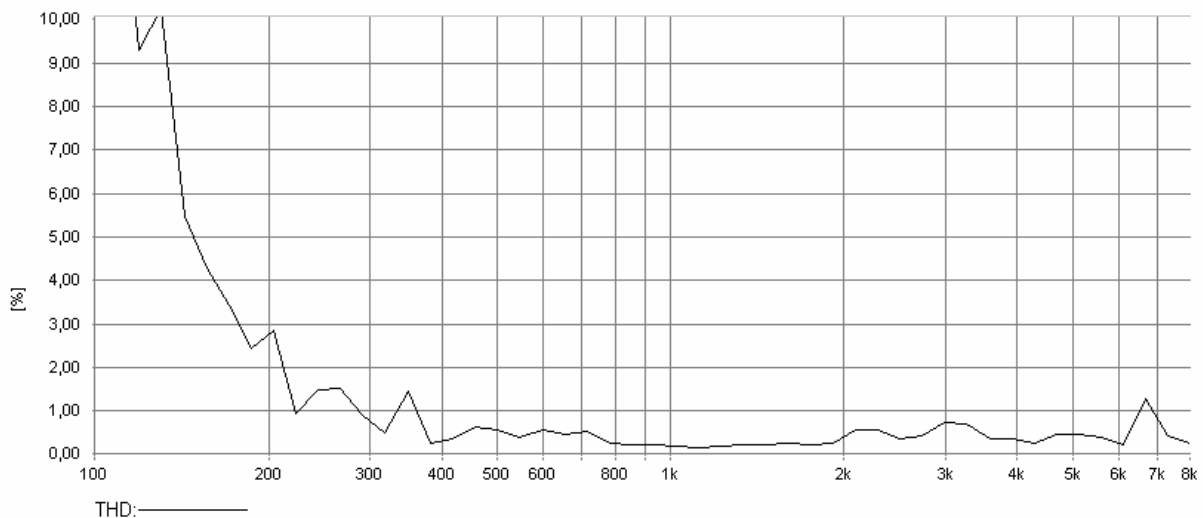

The curve shows a high distortion at 120Hz. This frequency is good for the test. At this frequency the voice coil of the speaker makes a high displacement. The test is for the correct placement of the voice coil.

The test frequency is always set for the range with high distortion.



46. With the QC button the quality measurement is to open.

47. In the case that the FR83/8 definition is not shown,

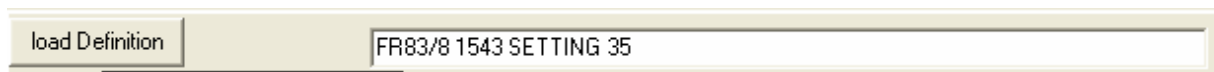

it is to load with load definition

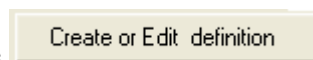

48. The definition menu is to open with the Create or Edit definition button.

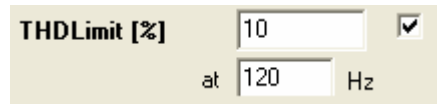

49. In this window the maximum value and the frequency for the distortion measurement are to set. With the mark the measurement is to activate for the test measurement.



50. With the button is to start a test measurement.



In the result display the distortion is shown. The display is green because the distortion is < 10%, set in the definition menu.

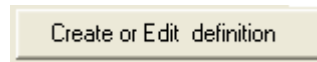

51. After going back in the definition menu with

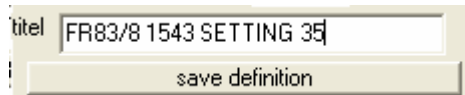

the definition is saved.

52 The definition for the polarity test



52. With the button the quality measurement is to open.

53. In the case that the FR83/8 definition is not shown,

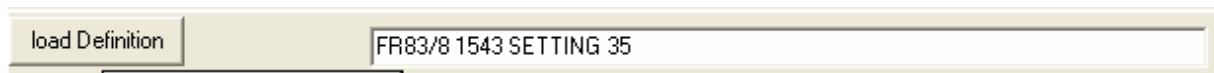

it is to load with load definition

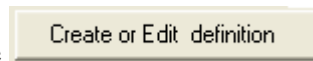

54. The definition menu is to open with the button.

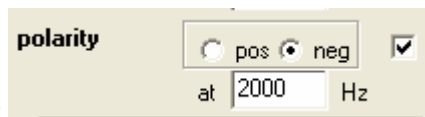

55. With the mark the measurement is to activate for the test measurement.

50. The +/- setting is a function of the speaker. Due to the acoustic measurement it is not defined. The polarity and test frequency are to find out by testing.



With the button the measurement is to start.



56. In the result display the result is shown. If the display is red, the polarity setting in the definition menu is to change.

There is to open the definition menu with the  button.

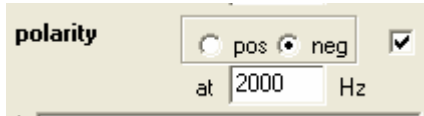

In the polarity window pos or neg is to change.

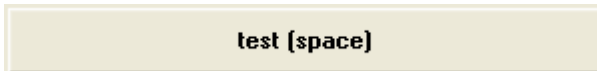

57. With the button some measurement are to start. If the colour of the result display change a new frequency is to set in the definition



To make the polarity test faster you can switch of the SPL, RB and THD measurement in the result display. The marks can be deleted with a click at the left mouse button

58. After going back in the definition menu with ,

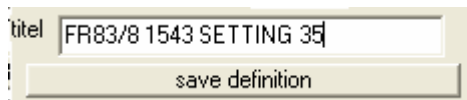

the definition is saved.

59 The Quality Control measurement

59. With the  button the quality measurement is to open.

60. With load Definition

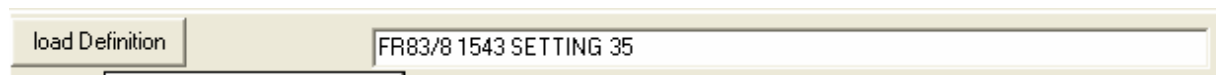

The definition is to load.

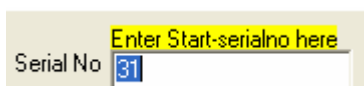

62. In the window for the first measurement the start serial number is to set. It could also be set with the barcode scanner. For the following measurement the number will automatically increase or set by the barcode scanner.

61. After connecting the speaker, the measurement is to start with the

test [space]

button.

62. The result is shown in the result display.

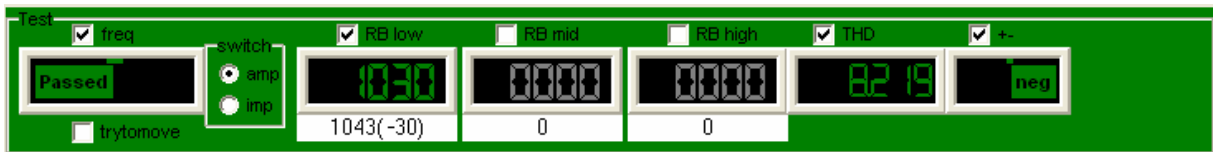

63. The result is write down in the report.

```
.....  
Polarity: failed  
25 :overall ??????????FAILED?????????  
Polarity: failed  
26 :overall ??????????FAILED?????????  
27 BMH : PASSED  
27 RB low : PASSED (Qindex=1029 from 1043)  
THD passed  
Polarity: failed  
27 :overall ??????????FAILED?????????  
28 BMH : PASSED  
28 RB low : PASSED (Qindex=1054 from 1043)  
THD passed  
Polarity: passed
```

64. By the end of the test measurements the report

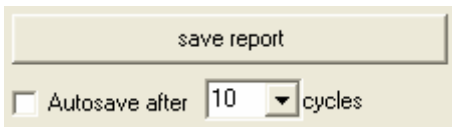

is saved.

65 Appendix
Measurement
box

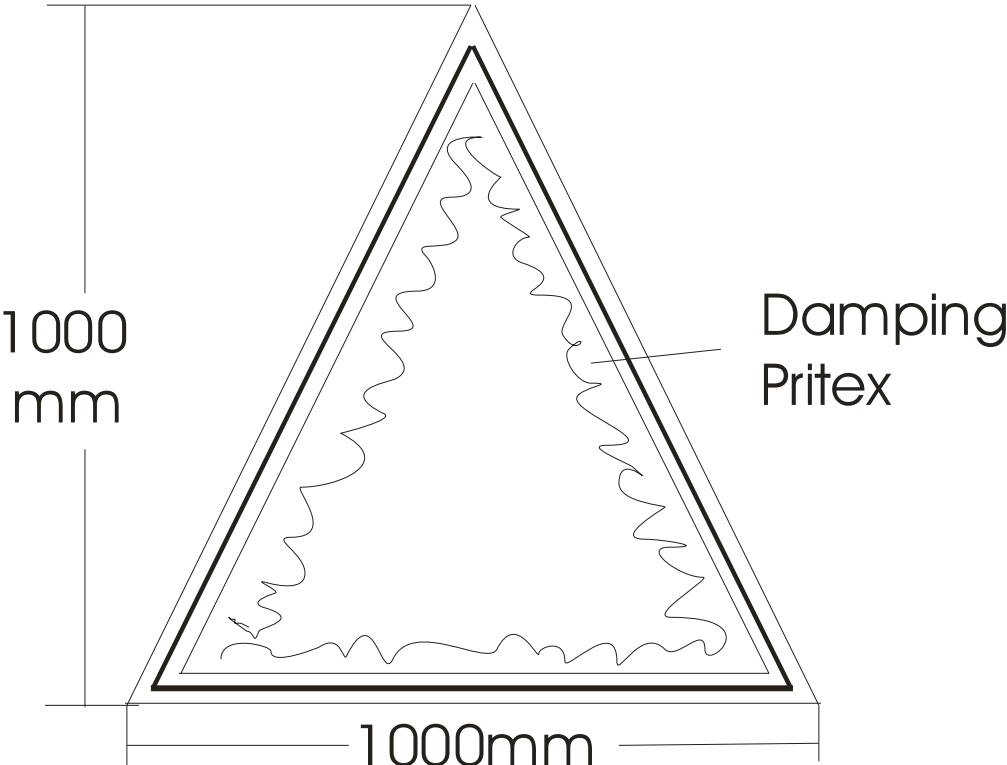
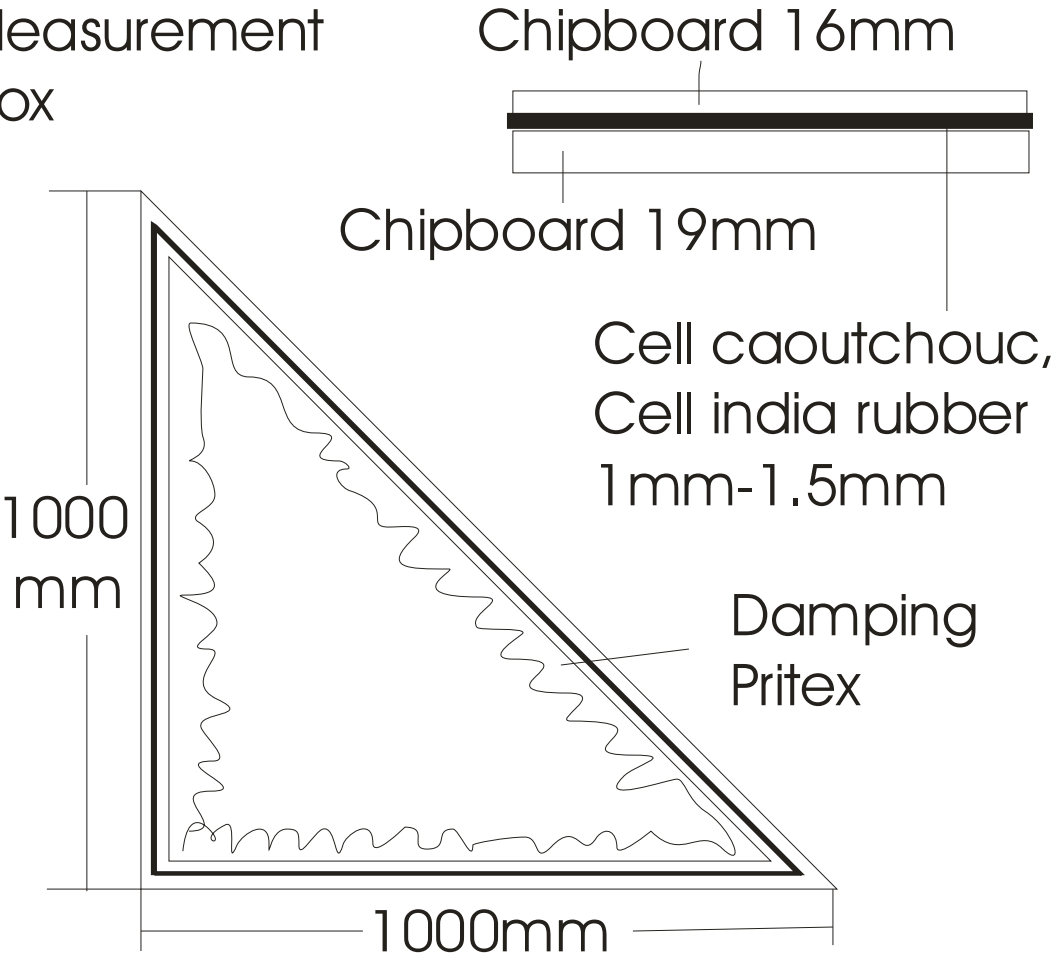

© 2007 Copyright Kirchner elektronik

Testing a speaker box

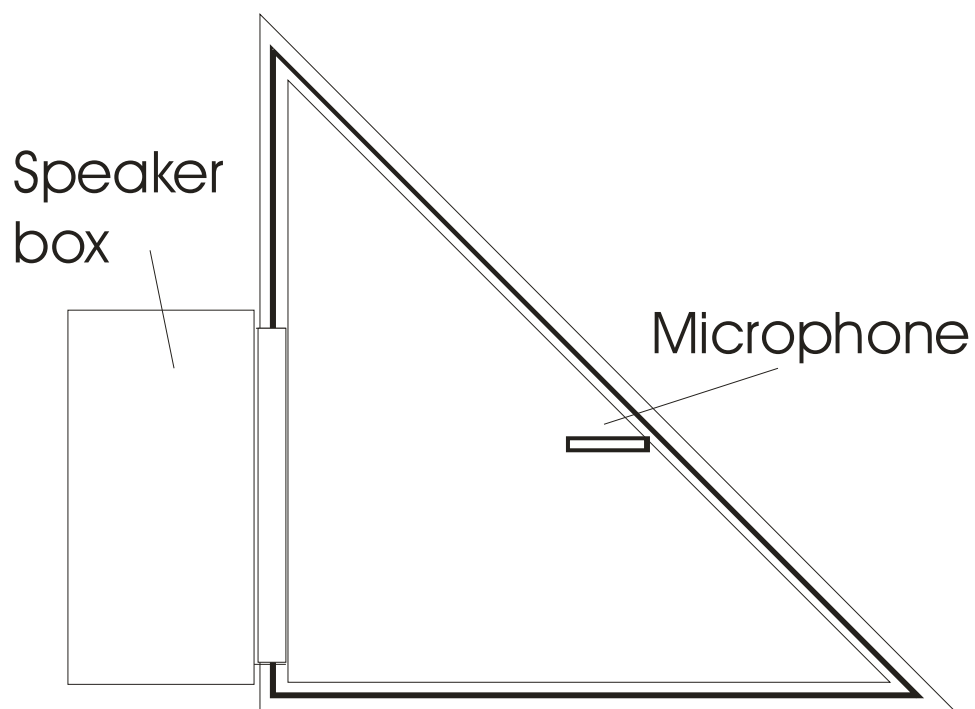
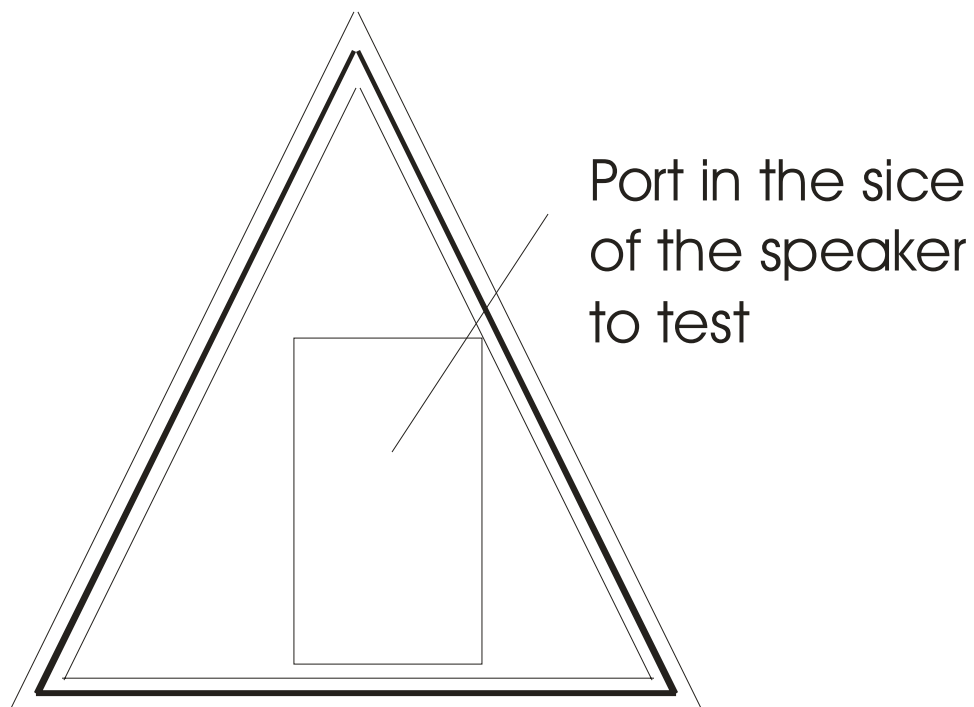

© 2007 Copyright Kirchner elektronik

Testing a speaker box

